

1300nm OPTICAL AMPLIFIER

Description

This semiconductor optical amplifier is intended for use in 1300nm transmission systems. Its high output saturation power level provides a compact and low cost amplification approach. The SOA amplifier package includes a thermistor and thermo-electric cooler in a 14-pin butterfly package with single mode fibre pigtailed.

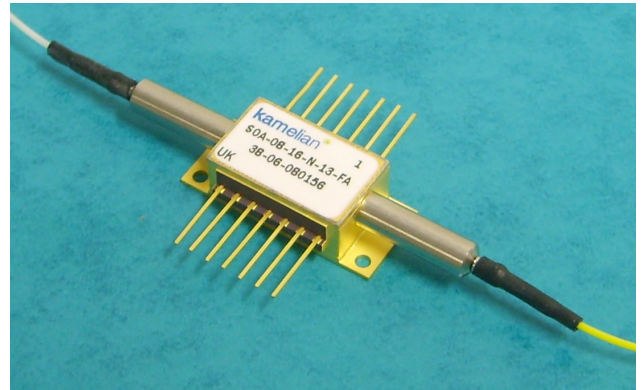

Applications

This product is appropriate for 1300nm systems including access, metro and regional applications where the SOA increases the signal power to overcome losses associated with for example, passive optical components. Typical applications include: SONET, IOGE, VSR, PONS, CATV and CWDM. Two variants are available - low gain (min 10dB) and high gain (min 16dB). The former is appropriate for use at a transmitter. The high gain variant is suitable for use as a pre-amp.

FEATURES

- 1300nm WINDOW
- HIGH SATURATION POWER
- LOW POLARISATION DEPENDENCE
- LOW NOISE FIGURE
- COMPACT PACKAGE
- MSA COMPLIANT

Specifications

(1280-1340 nm)

PARAMETER	MIN SPECIFICATION	TYPICAL SPECIFICATION	MAX SPECIFICATION
Fiber-to-fiber gain SOA-08-10*	10dB		
Fiber-to-fiber gain SOA-08-16*	16dB		
Noise figure (>5 dB gain)		6dB	7dB
Saturation output power*	8dBm		
Polarisation dependence		0.5dB	1.5dB
Gain ripple		0.5dB	0.8dB
Bias current		200mA	250mA
Operating temp	-5°C		70°C
TEC Drive Max		0.7A/1.5V	

* SOAs with a minimum gain of 18dB and saturation output power of 10dBm are available over a restricted 1300nm band of 1290 to 1320nm.

Pin Allocation & Package Dimensions

PIN	DEFINITION	PIN	DEFINITION
1	TEC +	8	NC
2	THERMISTOR	9	NC
3	NC	10	SOA ANODE (+)
4	NC	11	SOA CATHODE (-)
5	THERMISTOR	12	NC
6	NC	13	CASE GND
7	NC	14	TEC -

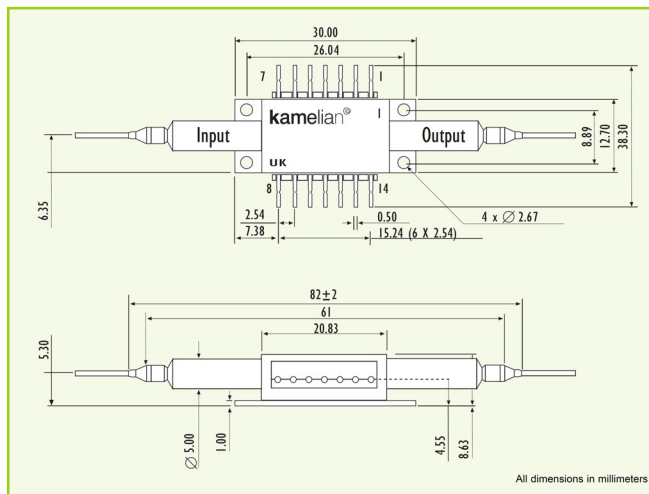

FIBER CONNECTOR	
CODE	CONNECTOR TYPE
FP	FC/PC
FA	FC/APC
FU	FC/UPC
LP	LC/PC
LA	LC/APC
LU	LC/UPC
SP	SC/PC
SA	SC/APC
SU	SC/UPC
∅	None

Ordering Information

SOA - XX - YY - N - W - ZZ

Output Power (08 for >8dBm is standard
10 for >10dBm on 13R only)

Gain (10 for >10dB, 16 for >16dB are standard
18 for >18dB on 13R only)

N = Non isolated is standard

Wavelength (13 for 1300nm Band and 13R for restricted 1300nm Band)

Connector Type (See Table Above)



Amphotonix reserves the right to make changes in design, specifications and other information at any time, and without prior notice. The information contained within this Data Sheet is believed to be accurate. However, no responsibility is assumed for possible inaccuracy or omission. Any information contained herein shall legally bind Amphotonix only if it is specifically incorporated into the terms and conditions of a sales agreement.

AMPHOTONIX LIMITED

4 Stanley Boulevard, Hamilton International Technology Park, High Blantyre, Glasgow, G72 0BN, United Kingdom
Tel: +44 (0) 1698 722074 Fax: +44 (0) 1698 821101 www.kamelian.com Email: amplifiers@amphotonix.com